

Propane-Fired Desiccant Dehumidifier for Residential and Small Commercial Applications

Paper # 60

2nd Global Technology Conference

21st World LP Gas Forum

September 26th, 2008

Seoul, South Korea

presented by

Greg Kerr, Director of R&D
Propane Education and
Research Council (PERC)



Desiccant Dehumidifier Operations

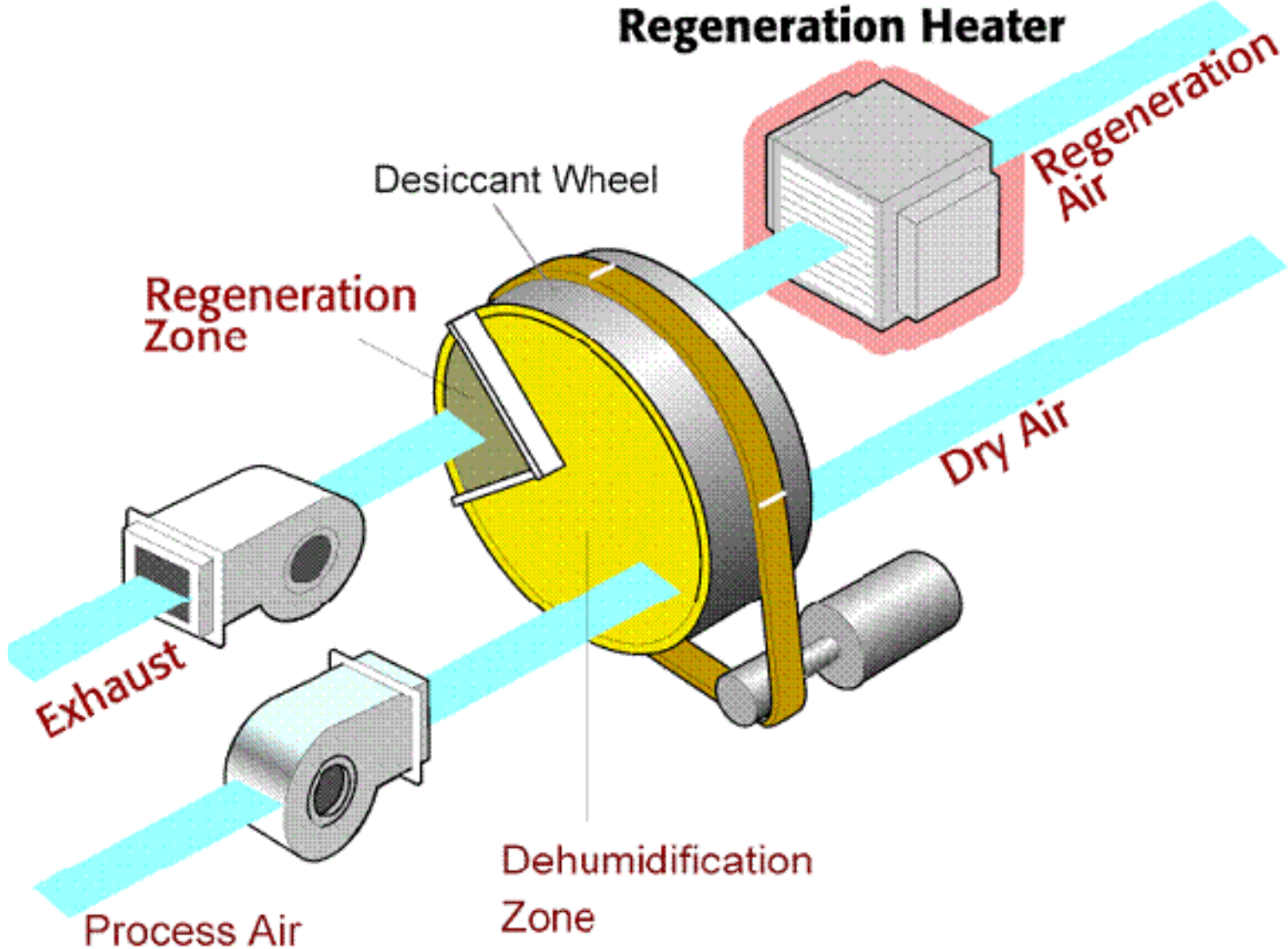

Emerging IAQ Applications

- **ASHRAE**
 - 65%RH design limit
 - Supplemental dehumidification may be needed
- **Sterling/ACAAI**
 - Maintain between 40% and 60%RH
 - Dehumidifying down to 45%RH beneficial to health, especially allergic/asthmatic individuals

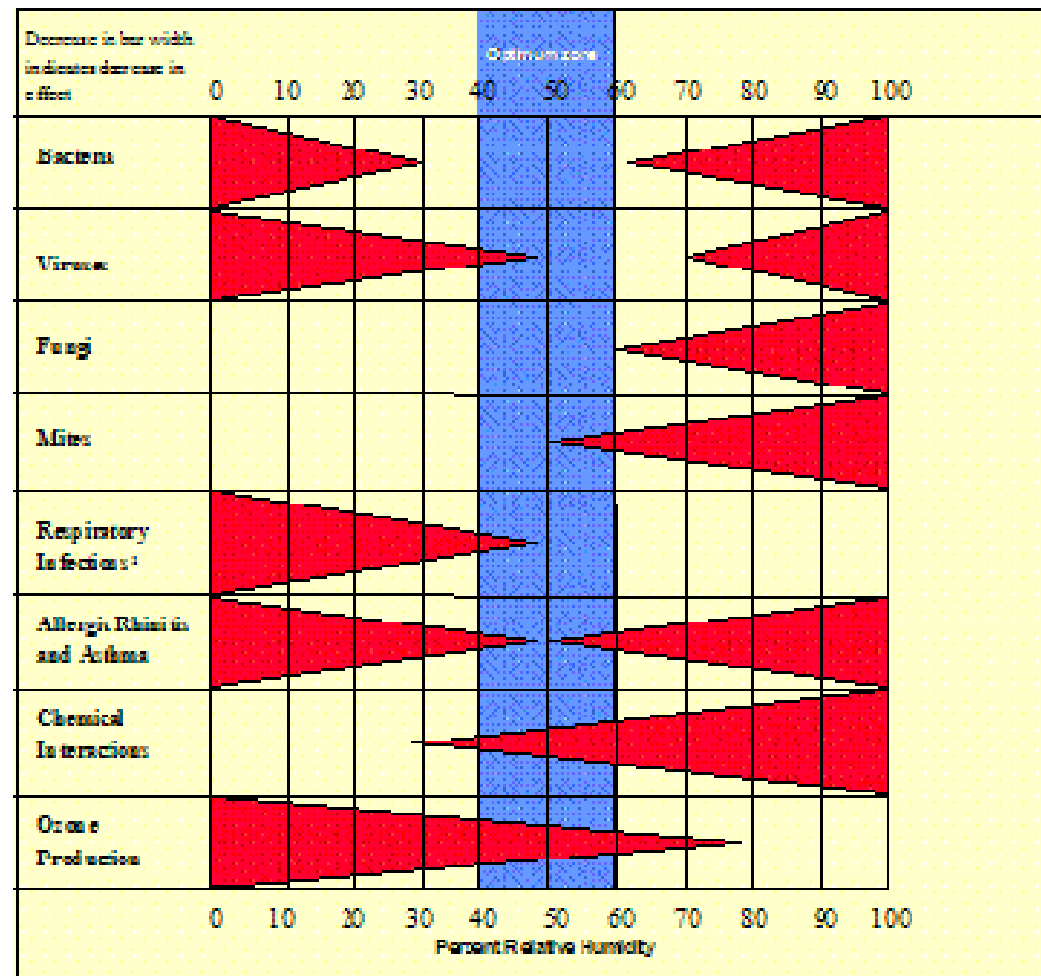

Evolutionary Development



- **First generation product (DD-400)**
 - Field tests
 - Certification tests
- **Reengineering project**
 - Weight and size reduction
 - Cost reduction
- **Second generation product (ComfortDry™ 400)**
 - Reliability tests
 - Other upcoming performance tests
 - Laboratory
 - Field

Field Tests (DD-400)

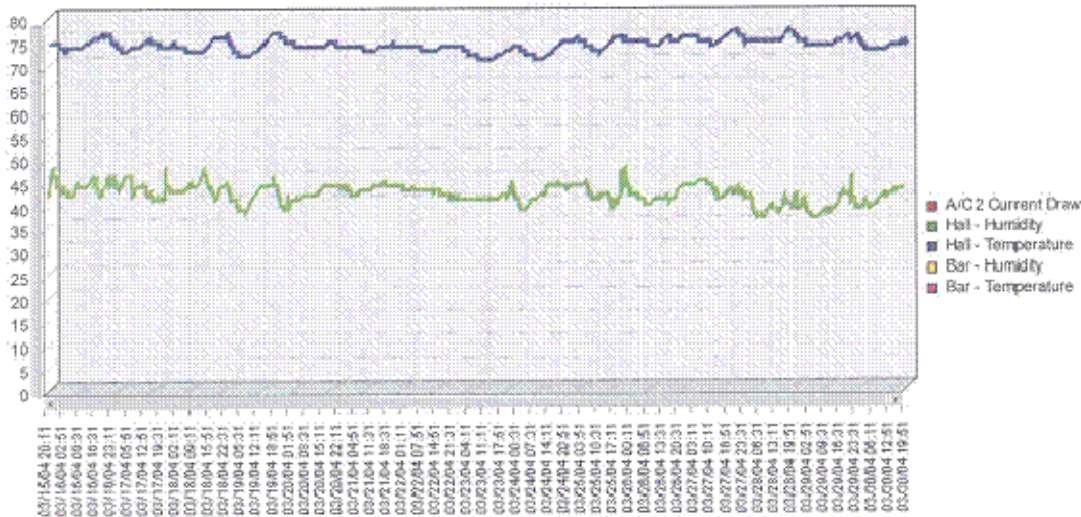

- Typical average of 45 %RH reached
- Large deadband with mechanical dehumidistat

- Dust mites decreased, often significantly, as humidity control was achieved in the homes

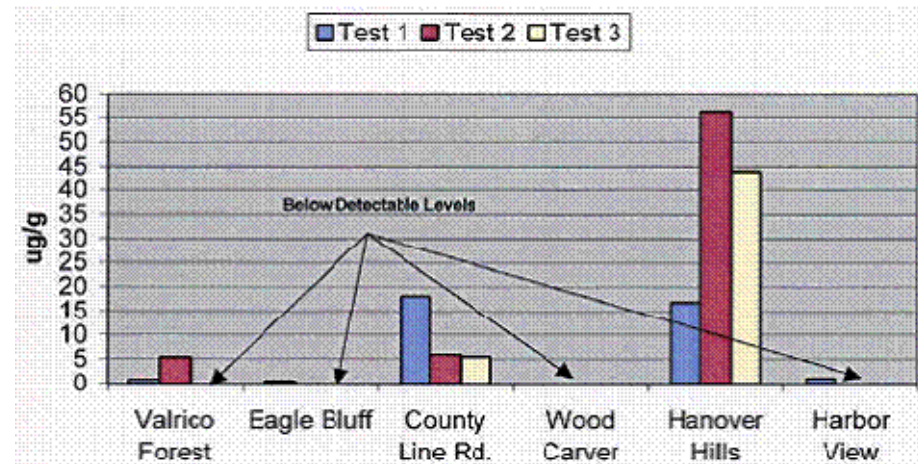

Certification Tests (DD-400)

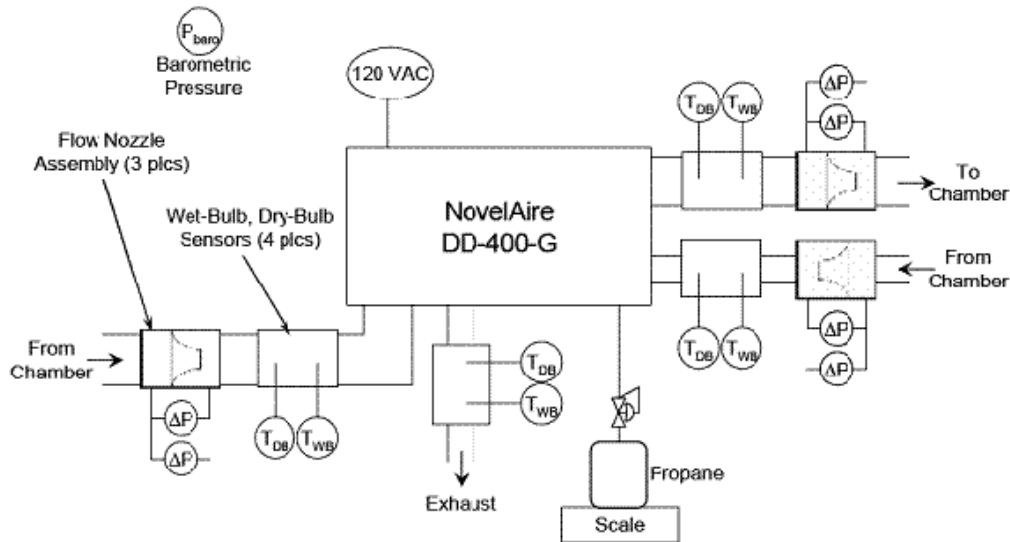

- DD-400 had significantly lower capacity than projected

- Several upgrades for reengineering
 - Process blower
 - Desiccant wheel housing and seals

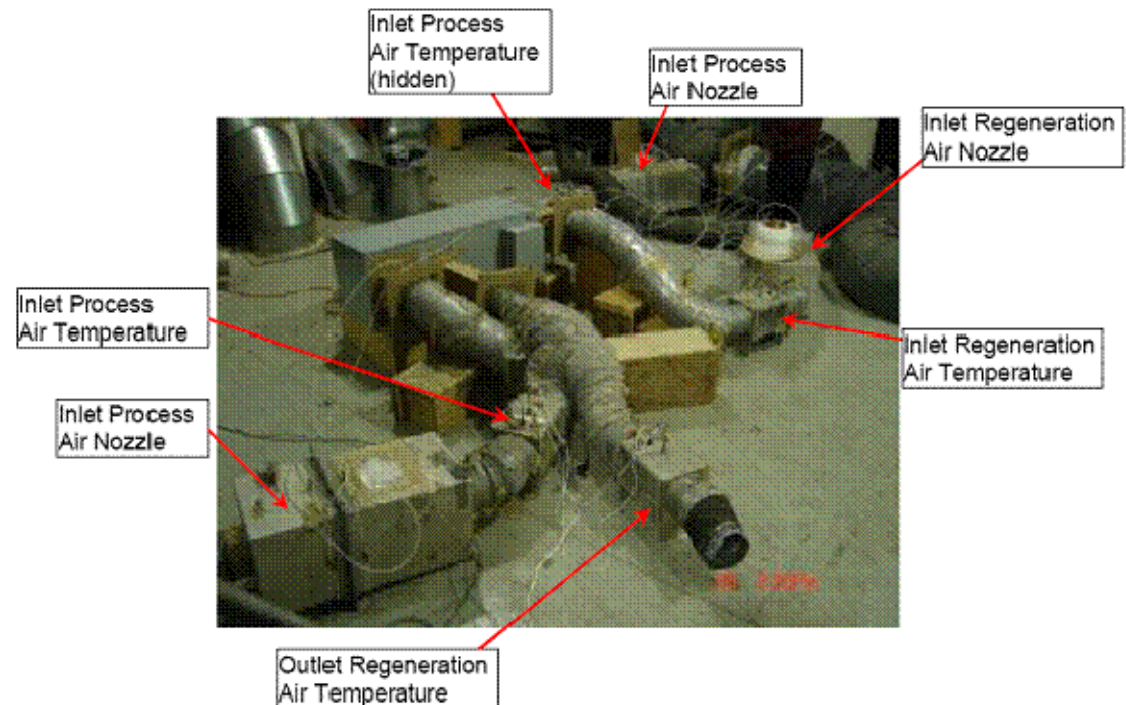

Reengineering Project

Lowered size, weight and cost

- Inexpensive burner design
- Standard (furnace) controller
- Other standard blowers/motors
- Integrated wheel/unit housing

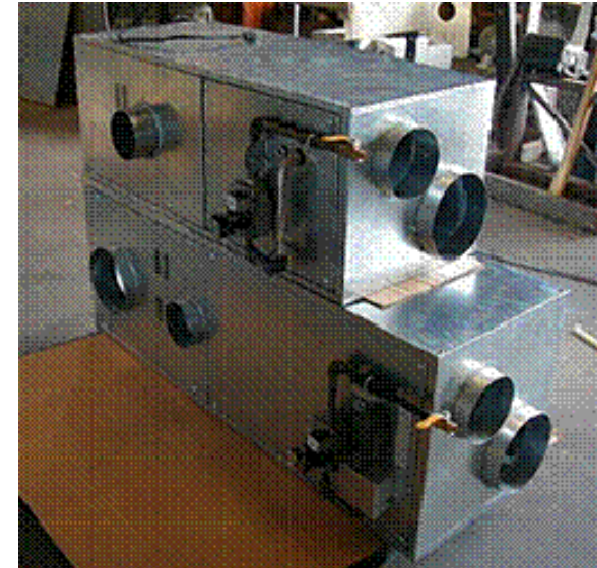

	ComfortDry™ 400	DD 400-G	Reduction	Target
Height	16"	20"	20%	NA
Length	42.5"	54"	21%	10%
Width	17.5"	17.5"	No Change	NA
Weight	130 lb	200 lb	35%	20%
Cost	\$1,900	\$2,500	24%	35%

Reliability Tests (ComfortDry™ 400)



Ongoing Accelerated Life Reliability Test Key Results

- high temperature faults
- failed drive components



Week #	2008 Dates	Dehumidistat Calls	Firing Statistics				Fault Statistics	
			1st Fire	2nd Fire	3rd Fire	Lockouts	High Temp	Low Airflow
1	4/18 - 4/24	869	819	41	7	2	0	0
2	4/24 - 5/1	994	968	24	2	0	46	0
3	5/1 - 5/8	1011	1005	6	0	0	504	0
4	5/8 - 5/15	878	871	7	0	0	0	0
5	5/15 - 5/22	1019	1013	6	0	0	11	0
6	5/22 - 5/27	720	714	6	0	0	185	0
7	5/27 - 6/5	1307	1298	9	0	0	26	0
8	6/5 - 6/12	1003	997	6	0	0	41	0
9	6/12-6/17	720	714	6	0	0	173	0
10	6/17-6/23	852	847	4	1	0	0	0
11	6/23-7/3	1324	1312	11	1	0	0	0
12	7/3-7/10	998	992	6	0	0	0	0
13	7-10-7/17	1012	1006	6	0	0	0	0
14	7/17-7/24	1010	1005	5	0	0	0	0

loose drive gear pulley

1st failing drive motor

2nd failing drive motor replaced with higher torque motor

Lab Tests (ComfortDry™ 400)

PROPANE
EXCEPTIONAL ENERGY®

Upcoming Performance Test Plans in the Lab

- Test duct built
- In shakedown
- Tests being planned
 - unit baselines
 - reliability issues
 - field operations
 - unit pre-certifications



Field Tests (ComfortDry™ 400)



Upcoming Performance Test Plans for the Field

- Site selection complete in Florida, Mississippi, Texas, and Missouri
- 8 of 20 installations made
- Monitoring underway
 - Dehumidifier run time
 - Temperature and %RH
 - Indoors
 - Outdoors



Consumer Application Economics



Establishment of supplemental dehumidification

- Requires understanding of roles for temperature and humidity in establishing comfort
- Needs valuation of improved comfort, health, etc.
- Weakens with recent increases in propane costs

Dehumidifier		Propane				Electricity				Total
Year	Hours/Year	Btuh	Gallons	\$/Gallon	\$/Year	Watts	kWh	\$/kwh	\$/Year	\$/Year
2004	1000	10000	109	1.60	175	400	400	0.09	36	211
	2000	10000	219	1.60	350	400	800	0.09	72	422
2008	1000	10000	109	2.80	306	400	400	0.11	44	350
	2000	10000	219	2.80	612	400	800	0.11	88	700

Summary

- Desiccant dehumidifiers emerging alternative
- Evolution of improving generations of products
- Advancements in reliable control of excessive humidity levels and potential benefits to occupant health and building maintenance
- Increasing price of propane puts pressure on future operating energy cost scenarios
- Avoided IAQ/health and mold/maintenance costs need to become a growing part of the overall economic justification for cost effective application of supplemental dehumidification

Acknowledgements



- **Coauthors**
 - Douglas Kosar, Gas Technology Institute
 - Neil Leslie, Gas Technology Institute
 - Steve Jaeger, Texas Railroad Commission
 - Scott Janke, NovelAire Technologiesand special thanks to Ralph Terrell of TECO Partners
- **Past and present sponsors**
 - Propane Education and Research Council
& propane industry partners
 - Gas Technology Institute & gas industry partners
 - NovelAire Technologies